

Multi utility connection for buildings with basement



UTILITY - ENTRIES



KRASO® Builder's Convenience Box - wall - NFE

Comfortable connection to your basement: heat pump, local, district or geothermal heating

- + Heat pump or local, district or geothermal heating system connection each with supply and reflux!
- + For heat pumps or local, district or geothermal heating lines with diameter 110, 90, 75, 50, 40 or 32 mm, optionally available with a diameter of 125 mm
- + For core drilling and casing DN 300 (299 - 303 mm). For precast walls and in-situ concrete walls!
- + External sealing element with sealing flange according to DIN 18533! Seal width: 90 mm
- + Gas- and odour-tight - high-quality in terms of TA-Air!
- + Certified up to 1 bar!
- + Radon tightness IAF tested - according to FHRK leaflet MB 101! Resistant to methane gas!
- + **Torque Control Nut KRASO® DKM:** integrated torque limiter - no torque wrench required!
- + Including all components for a secure grid connection of heat pump, local, district or geothermal heating, water, electricity and telecommunication!
- + Including casing pipe end plugs - warm bridges are avoided!
- + Optionally available: **KRASO® BKP - wall - NFE - Extension Set** - for cable protective hoses, **KRASO® FLS** or rigid casing pipes!
- + DafStB waterproof concrete guideline: stress class 1 + 2, DIN 18533 W1 -E and W2.1 -E

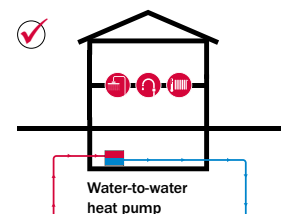
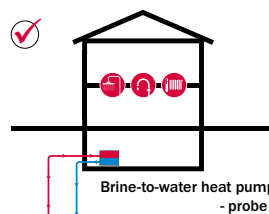
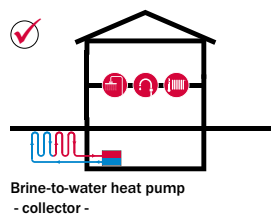
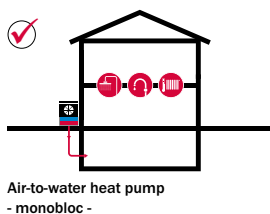

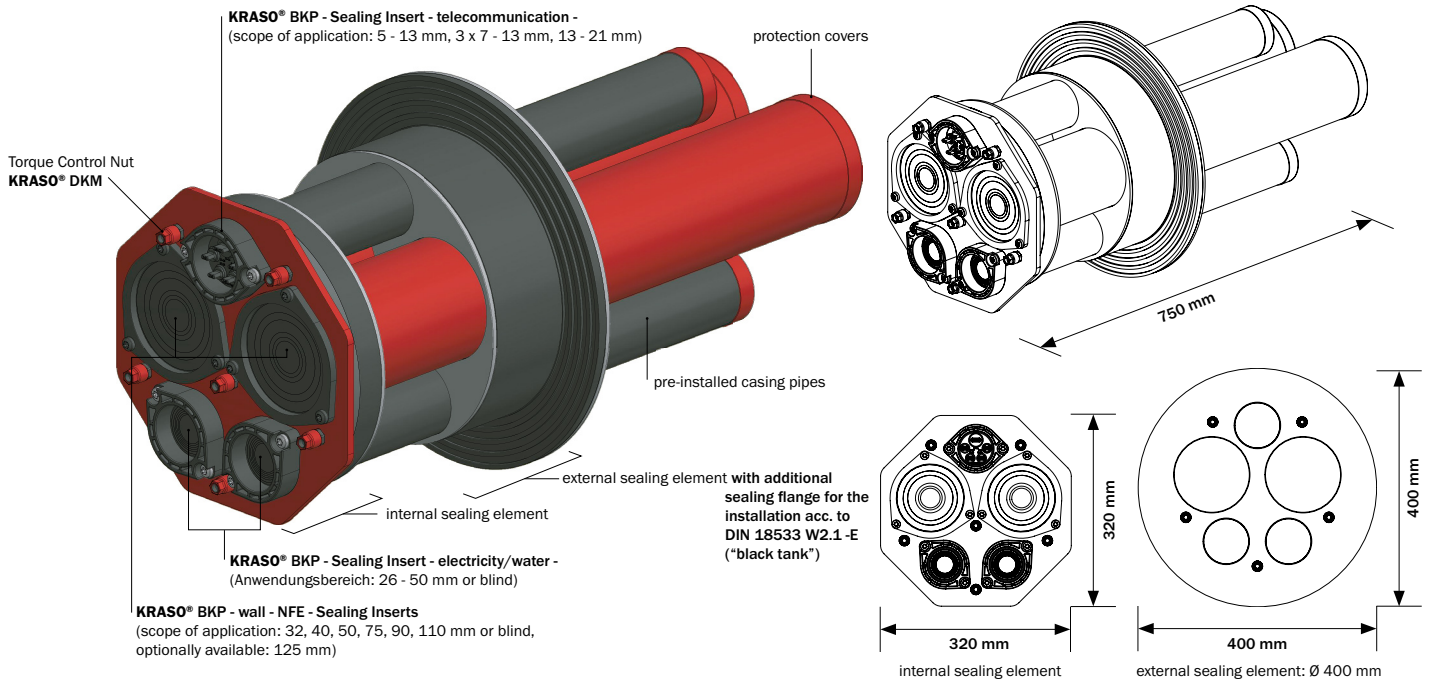

KRASO® Builder's Convenience Box - wall - NFE **LG5**

multi utility connection for supply lines (local, district or geothermal heating, water, electricity, telecommunication) for buildings with basement | DafStB waterproof concrete guideline: stress class 1 + 2, DIN 18533 W1 -E and W2.1 -E

Item	KRASO® BKP - wall - NFE
Wall thickness from ... to ... in mm	200 - 500
Diameter core drilling min ... max ... in mm	299 - 303
Length complete system in mm	750
Length x width internal sealing element in mm	320 x 320
Diameter external sealing element in mm	400
Seal width external sealing element in mm	90
Internal diameter casing pipes in mm	68
External diameter casing pipes in mm	75
Internal diameter casing pipes NFE in mm	118
External diameter casing pipes NFE in mm	125
KRASO® BKP - wall - NFE	1,225 €

Scope of supply: KRASO® Builder's Convenience Box - wall - NFE including

- internal sealing element with 5 casing pipes for the installation of supply lines for heat pump, local, district or geothermal heating (supply and reflux), water, electricity and telecommunication incl. protection covers
- external sealing element
- installation instructions **KRASO® BKP - wall - NFE**
- installation kit including
 - **KRASO® BKP - wall - NFE - Sealing Insert** - 2 pcs. scope of application: 32, 40, 50, 75, 90, 110 mm or blind, optionally available: 125 mm
 - primary sealing + secondary sealing NFE
 - 2 x end plug NFE
 - 2 x hose connection 125/125

- **KRASO® BKP - Sealing Insert - electricity/water** - 2 pcs. with stepless onion ring technology 26 - 50 mm or blind
 - primary sealing + secondary sealing electricity/water
 - casing pipe end plugs including
 - end plug electricity/water - split -
 - hose connection 80
- **KRASO® BKP - Sealing Insert - telecommunication** - clamping range: 5 - 13 mm, 3 x 7 - 13 mm, 13 - 21 mm
 - primary sealing + secondary sealing telecommunication
 - casing pipe end plugs including:
 - end plug telecommunication - split -
 - hose connection 80

optionally available:

- **KRASO® BKP - wall - NFE - Extension Set**

Further wall thicknesses available on request!