

... for more than 40 years +

KRASO®

SIMPLE + TIGHT



All rights to the drawings and designs are the property of KRASO GmbH & Co. KG. •
Reproduction and distribution of the drawings as well as any other use require our written consent. •



KRASO® Inject LR

Installation instructions



KRASO GMBH & CO. KG
Baumannweg 1 | DE-46414 Rhede
T +49(0)28 72 - 95 35-0
info@kraso.de | **KRASO.de**

1.26-MA.EN-v1.0-05.26-RSc.DK

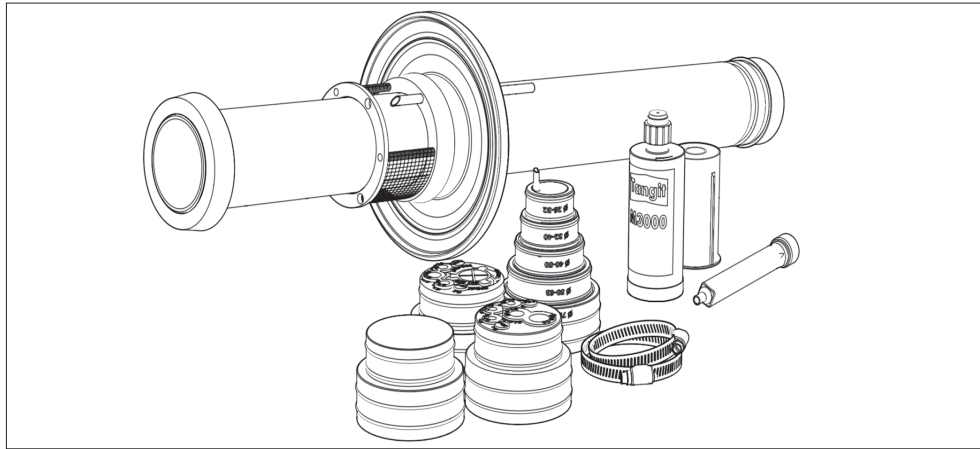

KRASO® Inject LR

Empty pipe as recess for retrofit installation of cables and pipes using a casing pipe end plug (electricity/water, telecommunication or fibreglass), with injection system.

| DIN 18533 W2.1 -E, DafStB waterproof concrete guideline: stress class 1 + 2

1. Creating a hole. See image for minimum distances and core drilling diameters.
2. Preparation of the house connection. Set control mark **A** - position of the control mark **B** - wall thickness **C** - position of the control mark "external sealing" of further **50 mm**.
or
3. Preparation of the house connection with casing pipe connection. Set control mark **A** - position of the control mark **B** - wall thickness **C** - position of the control mark "external sealing" of further **50 mm**. **D** - protrusion **50 mm**.
4. Remove protective film.
5. Insert **KRASO® Inject LR** into the core drilling/casing from the outside of the building.
Please note that the butyl tape must not touch the external wall when the external sealing is aligned.
6. Align the external sealing and house connection according to the marking on the large ring ("top") and the markings on the house connection.
7. Push the external sealing up to the external wall, noting the position of the control mark and correcting it if necessary.
8. Unscrew the cap of the resin cartridge (Tangit M 3000, 300 ml) and screw the cartridge into the static mixer.
9. Connect the static mixer firmly to the filling pipe as far as it will go.
10. Remove the bottom cap of the resin cartridge. Insert the resin cartridge into the cartridge gun. Using steady movements, inject the resin completely from the cartridge into the **KRASO® Inject LR** using the cartridge gun.
- 11.* Tightening the IDK nuts. For final assembly, tighten the 4 or 5 nuts (spanner size 10 or 13). Continue until the upper nuts come off.
12. Remove the protective cap and slide the casing pipe end plugs onto the end of the sleeve (on the outside of the building). If a casing pipe is being connected, the casing pipe end plug must be slid onto the end of the sleeve (on the inside of the building).
13. Tighten the hose clamp (Ø 70–90 mm) used to secure the casing pipe end cap to a torque of 3 Nm.
14. Place the profile seals **A** upright in the second corrugation trough of the casing pipe and in the groove of the sleeve pipe. Then grease both profile seals (lubricant) and push the casing pipe into the double plug-in sleeve together with the casing pipe onto the sleeve pipe.



Safety instructions: protect the house connection from damage, moisture and contamination during installation. Check all individual parts for possible damage. Only undamaged parts may be installed. When installing the house connection, the relevant regulations of the professional associations, the VDE regulations, the relevant national safety and accident prevention regulations and the guidelines (work and process instructions) of your company must be observed. We expressly point out that no warranty is provided for any consequential damage that may occur if the information in the installation instructions is not followed, if our products are used improperly or if they are combined with third-party products.
Danger: expansion resin: Tangit M3000 (300 ml). Contains diphenylmethane-4,4'-diisocyanate. Observe the manufacturer's instructions.
Recycling/disposal: empty packaging can be disposed of via the dual system (yellow bin/bag in Germany). Cured polyurethane residues can be disposed of with household waste/commercial waste.

