

TECHNICAL DATA SHEET

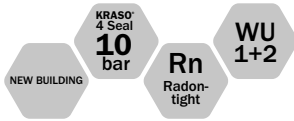

KRASO® Yard-/Parking Level Drain with stainless steel grate Type 1.5

Application areas

Drain for the drainage of grey water, for installation in areas with moderate traffic.

Technical details

- + In accordance with DIN EN 1253
- + Connection either for KG, HT or KG 2000 pipes DN 110, vertical drain
- + Load class A up to 1.5 t
- + Drainage capacity: 4.3 l/s
- + With frost proof odour barrier and removable sand trap basket, with slot grate 19 x 19 cm and frame made of stainless steel, screwed
- + Base plate thickness at least 17 cm

Tests

- + KRASO® 4 Seal - MPA-tested up to 10 bar!
- + IAF-tested: radon-tight!
- + DafStB waterproof concrete guideline: stress class 1 + 2



Material

Main body	ABS
Insert frame & grating	ABS & non-corrosive stainless steel V2A
4 seal	PVC

TECHNICAL DATA SHEET

KRASO® Yard-/Parking Level with stainless steel grate Type 1.5

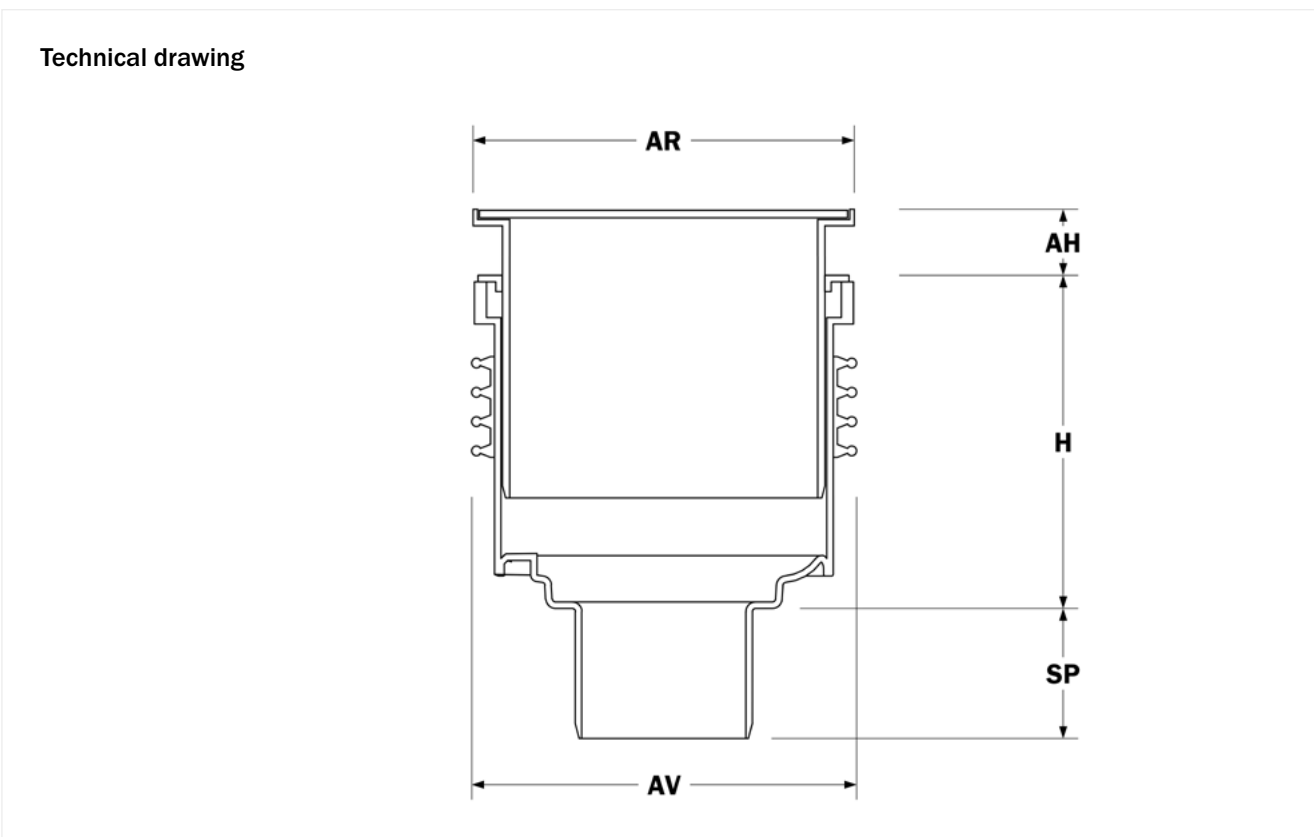

H = height main body | SP = spigot | AH = height insert frame | AR = insert frame | AV = 4 seal exterior

Item	H (mm)	SP (mm)	AH (mm)	AR (mm)	AV (mm)	Ø Pipe connection (mm)	Weight (kg)	Item no.
Yard-/Parking Level Drain with stainless steel grate Type 1.5	205	80	25 - 60	204 x 204	~238	DN 110	3.0	KHA15E