

TECHNICAL DATA SHEET

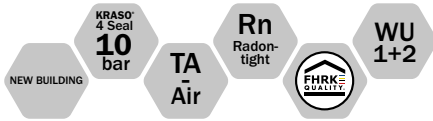

KRASO® Casing Type FE

Application areas

True diameter casing for the installation in waterproof concrete constructions, for retrofit installation of cables or pipes using a sealing insert.

Technical details

- + Thick-walled true diameter plastic casing for concreting
- + Material and processing: weatherproof, impact-resistant plastic, **KRASO® 4 Seal** joined monolithically to the plastic pipe by vulcanization
- + Low weight: easy handling, simple installation
- + Including installation covers
- + High-quality in terms of TA-Air
- + Certified with the quality seal of the FHRK e. V.

Tests

- + **KRASO® 4 Seal** - MPA-tested up to 10 bar!
- + IAF-tested: radon-tight!
- + DafStB waterproof concrete guideline: stress class 1 + 2



Material

Casing	PVC
4 seal	PVC
Installation covers	PP

TECHNICAL DATA SHEET

KRASO[®] Casing Type FE

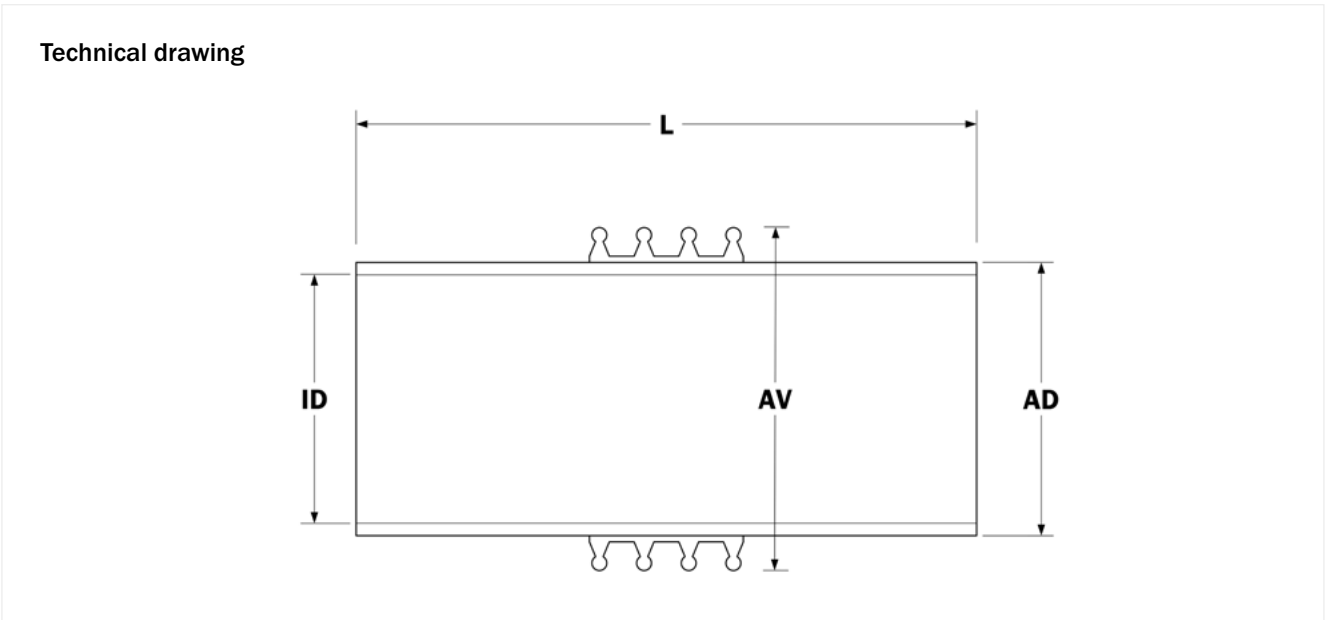

ID = pipe internal | AD = pipe external | AV = 4 seal external | L = wall thickness

Item

Casing Type FE										
ID (mm)	80									
AD (mm)	85									
AV (mm)	113									
L (cm)	20	24	25	30	35	36.5	40	45	50	
Weight (kg)	0.5	0.5	0.6	0.7	0.8	0.8	0.8	0.9	1.0	
Item no.	KFE080 200	KFE080 240	KFE080 250	KFE080 300	KFE080 350	KFE080 365	KFE080 400	KFE080 450	KFE080 500	
ID (mm)	100									
AD (mm)	110									
AV (mm)	138									
L (cm)	20	24	25	30	35	36.5	40	45	50	
Weight (kg)	0.7	0.8	0.8	0.9	1.1	1.1	1.2	1.3	1.5	
Item no.	KFE100 200	KFE100 240	KFE100 250	KFE100 300	KFE100 350	KFE100 365	KFE100 400	KFE100 450	KFE100 500	

Dimensional and weight data without guarantee • Variations in colour possible • Subject to technical changes • All rights to the drawings and designs are the property of KRASO GmbH & Co. KG • The copying and distribution of drawings and other use require our written consent.

TECHNICAL DATA SHEET

KRASO® Casing Type FE

Item

Casing Type FE										
ID (mm)	125									
AD (mm)	134									
AV (mm)	162									
L (cm)	20	24	25	30	35	36.5	40	45	50	
Weight (kg)	1.0	1.2	1.2	1.4	1.6	1.7	1.8	2.1	2.3	
Item no.	KFE125 200	KFE125 240	KFE125 250	KFE125 300	KFE125 350	KFE125 365	KFE125 400	KFE125 450	KFE125 500	
ID (mm)	150									
AD (mm)	158									
AV (mm)	186									
L (cm)	20	24	25	30	35	36.5	40	45	50	
Weight (kg)	1.2	1.4	1.4	1.7	1.9	2.0	2.2	2.4	2.7	
Item no.	KFE150 200	KFE150 240	KFE150 250	KFE150 300	KFE150 350	KFE150 365	KFE150 400	KFE150 450	KFE150 500	
ID (mm)	200									
AD (mm)	208									
AV (mm)	236									
L (cm)	20	24	25	30	35	36.5	40	45	50	
Weight (kg)	1.3	1.5	1.5	1.8	2.0	2.0	2.2	2.5	2.7	
Item no.	KFE200 200	KFE200 240	KFE200 250	KFE200 300	KFE200 350	KFE200 365	KFE200 400	KFE200 450	KFE200 500	

TECHNICAL DATA SHEET

KRASO® Casing Type FE

Item

Casing Type FE										
ID (mm)	250									
AD (mm)	260									
AV (mm)	288									
L (cm)	20	24	25	30	35	36.5	40	45	50	
Weight (kg)	1.8	2.1	2.1	2.5	2.9	2.9	3.2	3.6	3.9	
Item no.	KFE250 200	KFE250 240	KFE250 250	KFE250 300	KFE250 350	KFE250 365	KFE250 400	KFE250 450	KFE250 500	
ID (mm)	300									
AD (mm)	315									
AV (mm)	343									
L (cm)	20	24	25	30	35	36.5	40	45	50	
Weight (kg)	2.3	2.6	2.7	3.2	3.6	3.7	4.1	4.5	5.0	
Item no.	KFE300 200	KFE300 240	KFE300 250	KFE300 300	KFE300 350	KFE300 365	KFE300 400	KFE300 450	KFE300 500	