

TECHNICAL DATA SHEET



KRASO® System Cover KDS 150 with sleeve

Application areas

System cover KDS 150 with sleeve for installation in **KRASO®** Cable Penetration.

Technical details

- + Incl. bayonet fitting with union nut and anti-twist lock (prevents accidental opening)
- + With sleeve for the connection of PVC and PP pipes to **KRASO®** Cable Penetration KDS 150

Tests

- + Certified with the quality seal of the FHRK e. V.



Material

System cover	PC
Union nut	ABS
Sleeve	PVC*
Rubber ring	EPDM

*can be replaced with PP if necessary

TECHNICAL DATA SHEET

KRASO® System Cover KDS 150 with sleeve

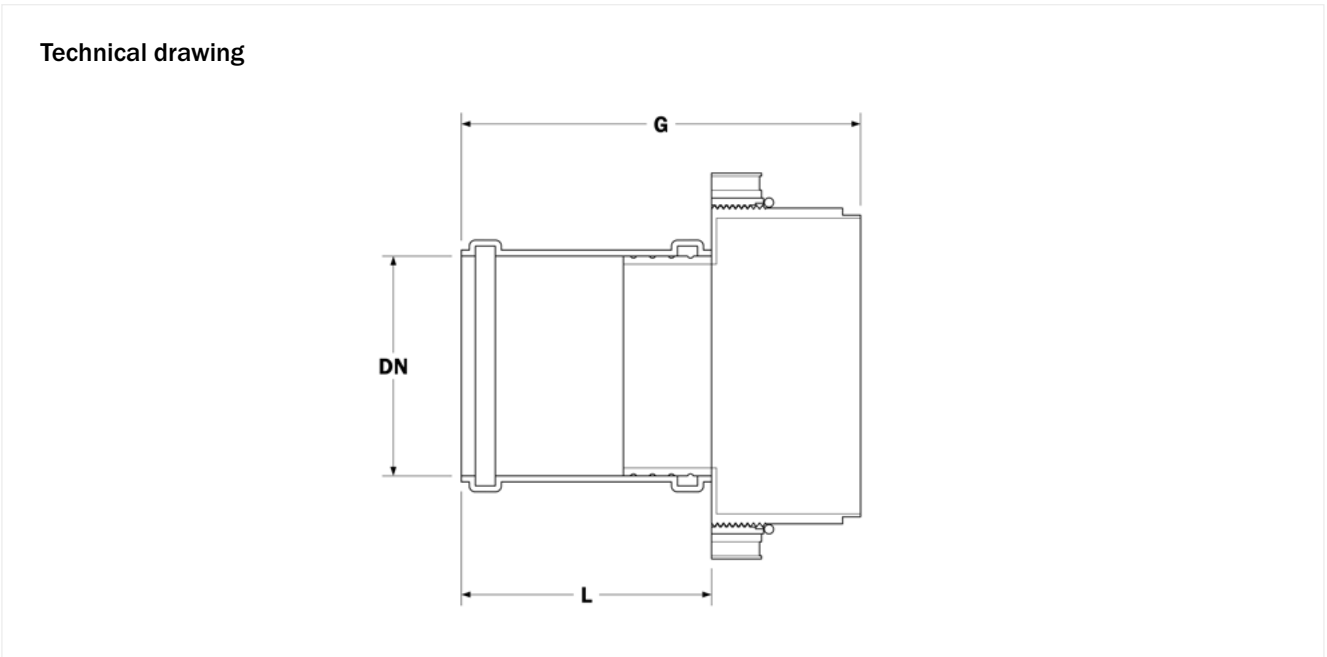

G = total length | **L** = spigot length

Item		G (mm)	L (mm)	Weight (kg)	Item no.
System Cover KDS 150 with sleeve	DN 110	210	125	0.9	KKDS150SD110M
	DN 125	360	280	1.7	KKDS150SD125M
	DN 160	270	194	1.1	KKDS150SD160M